

Design and Manufacturing of Flange Yoke Fixture for milling machine

Sushmita Pandey⁽¹⁾ Kamesh Patil⁽²⁾, Sandip Gite⁽³⁾

Lecturer of Mechanical Engineering Department
GGSP, Nashik

shushmitapandey@ggsf.edu.in, kamesh.patil@ggsf.edu.in

Abstract—Flange Yoke is a part of Drive Shaft which is required when power is to be transmitted from engine to differential of an automobile. A flange yoke for a universal joint is used to join fork halves; each comprising a base component and a bearing component. During spot facing on the flange, vibrations takes place and it leads to tool breakage. Hence the tool changing time is increased. Thus there is a need to design a fixture to nullify the problems. We have designed such a fixture which will carry out the milling operation efficiently. The newly designed fixture uses an insert type of milling cutter which removes the material as per requirement, which reduces the vibrations and tool breakage and ultimately reduces the tool changing time..

Keywords—component; formatting; style; styling; insert

1. INTRODUCTION

1.1 Flange Yoke

A flange yoke for a universal joint comprises of a first and a second joint fork half which are joined to form the flange yoke. Each joint fork half having an element for receiving a pin and the element has a pin axis comprises of a base component and a bearing component. The base components of the first and the second joint fork halves being so shaped that they may form lock connected to form a flange. Flange Yoke 1130 is a part of propeller shaft assembly which is connected to the engine and differential. This flange is used in ambassador cars.[1]

1.2 Fixture: A fixture is a work-holding or support device used in the manufacturing industry. A fixture is a device used to “fix” (constrain all degrees of freedom) a workpiece in a given coordinate system relative to the cutting tool. Fixtures are used to securely locate (position in a specific location or orientation) and support the work, ensuring that all parts produced using the fixture will maintain conformity and interchangeability. Using a fixture improves the economy of production by allowing smooth operation and quick transition from part to part, reducing the requirement for skilled labor by simplifying how workpieces are mounted, and increasing conformity across a production run. The purpose of these devices is to reduce costs, and so they must be designed in such a way that the cost reduction outweighs the cost of implementing the fixture. It is usually better, from an economic standpoint, for a fixture to result in a small cost reduction for a process in constant use, than for a large cost reduction for a process used only occasionally.

Each component of a fixture is designed for one of two purposes: location or support.[1]

Location: Locating components ensure the geometrical stability of the workpiece. They make sure that the workpiece rests in the correct position and orientation for the operation by addressing and impeding all the degrees of freedom the workpiece possesses. For locating workpieces, fixtures employ pins (or buttons), clamps, and surfaces. These components ensure that the workpiece is positioned correctly, and remains in the same position throughout the operation. Surfaces provide support for the piece, pins allow for precise location at low surface area expense, and clamps allow for the workpiece to be removed or its position adjusted. Locating pieces tend to be designed and built to very tight specifications. Any rectangular body may have three axis along x-axis, y-axis and z-axis. It can move along any of these axes or any of its movement can be released to these three axes. At the same time the body can also rotate about these axes too. So total degree of freedom of the body along which it can move is six. For processing the body it is required to restrain all the degree of freedom (DOF) by arranging suitable locating points and then clamping it in a fixed and required position[1].

Support :In designing the locating parts of a fixture, only the direction of forces applied by the operation are considered, and not their magnitude. Locating parts technically support the workpiece, but do not take into account the strength of forces applied by the process and so are usually inadequate to actually

secure the workpiece during operation. For this purpose, support components are used.[1]

To secure workpieces and prevent motion during operation, support components primarily use two techniques: positive stops and friction. A positive stop is any immovable component (such as a solid surface or pin) that, by its placement, physically impedes the motion of the workpiece. Support components are more likely to be adjustable than locating components, and normally do not press tightly on the workpiece or provide absolute location. Support components usually bear the brunt of the forces delivered during the operation. To reduce the chances of failure, support components are usually not also designed as clamps.

1.2.1 Types of Fixture

A. Milling fixtures: Milling operations tend to involve large, straight cuts that produce lots of chips and involve varying force. Locating and supporting areas must usually be large and very sturdy in order to accommodate milling operations; strong clamps are also a requirement. Due to the vibration of the machine, positive stops are preferred over friction for securing the workpiece. For high-volume automated processes, milling fixtures usually involve hydraulic or pneumatic clamps.[4]

B. Drilling fixtures: Drilling fixtures cover a wider range of different designs and procedures than milling fixtures. Though work holding for drills is more often provided by jigs, fixtures are also used for drilling operations. Two common elements of drilling fixtures are the hole and bushing. Holes are often designed into drilling fixtures, to allow space for the drill bit itself to continue through the workpiece without damaging the fixture or drill, or to guide the drill bit to the appropriate point on the workpiece.[4]

C. Modular Fixtures: Modular fixtures achieve many of the advantages of a permanent tool using only a temporary setup. Modular work holders combine ideas and elements of both permanent and temporary work holding to make inexpensive-yet-durable work holders. The primary advantage of modular fixtures is that a tool with the benefits of permanent tooling (setup reduction, durability, productivity improvements, and reduced operator decision-making) can be built from a set of standard components. The fixture can be disassembled when the run is complete, to allow the reuse of the components in a different fixture. At a later time the original can be readily reconstructed from drawings, instructions, and photographic records. This reuse enables the construction of a complex, high-precision tool without requiring the corresponding dedication of the fixture components. [4]

1.3 Propeller Shaft: The function of anything with the word "propeller" on any vehicle is the object that

"propels" the vehicle, or makes it move. A propeller shaft on a car links between differential and transfer case. The engine essentially rotates the gears in transmission which in turn rotates the prop shaft itself, or the gears in the transfer case, which also rotates the propeller shaft. The shaft then turns the gears in the differential. The gears in the differential then turn the axles, which in turn rotate wheels, propelling the vehicle. As for an airplane, a propeller forces air in the direction of the rear of the plane thrusting (propelling) the plane forward. Same idea with a boat only it forces water back causing the boat to be propelled forward. A drive shaft, driveshaft, driving shaft, propeller shaft (prop shaft), or Cardan shaft is a mechanical component for transmitting torque and rotation, usually used to connect other components of a drive train that cannot be connected directly because of distance or the need to allow for relative movement between them. Drive shafts are carriers of torque: they are subject to torsion and shear stress, equivalent to the difference between the input torque and the load. They must therefore be strong enough to bear the stress, whilst avoiding too much additional weight as that would in turn increase their inertia. To allow for variations in the alignment and distance between the driving and driven components, drive shafts frequently incorporate one or more universal joints, jaw couplings, or rag joints, and sometimes a splined joint or prismatic joint.[4]



Fig No.1.1 Propeller shaft



Fig No.1.2 Flange Yoke 1130

2. DESIGN OF FIXTURE

The newly designed fixture is an Outer lug milling fixture. The milling operation is performed on the

flange yoke with the help of carbide insert milling cutter. The tool is 3 point 4 insert cutter. The tool is mounted vertically in the spindle of the head stock. Outer lug milling fixture is clamped on the worktable of conventional milling machine with the help of T-bolts.

The component i.e. the flange yoke is forged first. After the forging operation, the component goes through other operations like drilling, cross hole boring, grooving, facing, turning, chamfering. [3]

The final operation carried out on the newly designed fixture is a milling operation. To begin with the operation the component is mounted on the locator. The swing bolts are then inserted into the slots of the mandrel which is used to tighten the job on the locator. The mandrel is passed through the cross holes of the component. Then the assembly is checked for number of degrees of freedom. After giving the appropriate speed and feed to the machine, milling operation is carried out. The operation is carried out on the outer lug of the flange. One side is milled in one pass. The milling operation is done twice on the component. As milling operation is the final operation carried out on the flange, after the operation the component is ready for dispatch.[3]

DESIGN CALCULATION

Machining input parameters:-

- Tool used:- Carbide insert milling cutter – TNMG 20 X 20
- Diameter of cutter, D = 80mm
- Thickness of insert, B = 5mm
- Depth of milling across mounting holes, d1 = 2.5mm
- Depth of milling across cross hole side, d2 = 1mm
- Number of cutting edges in contact with workpiece, Z = 1

Selecting feed per tooth for milling operation on flange (SAE1140, 229-269 BHN)

- For side milling across mounting holes, S1 = 0.15mm
- For face milling across cross hole side, S2 = 0.25mm

Tangential Force

Tangential cutting Force in milling operation can be calculated from:

$$F_c = C_p \times d_x \times S_y \times Z \times B \times D^q$$

Where,

- Cp = Constant depending upon the characteristics of the tool material and material of job.
- d = Depth of milling in mm.
- S = Feed per cutting edges in mm.
- Z = No. of cutting edges in contact with workpiece.
- B = Width of milling cutter in mm.
- D = Diameter of cutter in mm.
- x, y, z and q are exponents.

For Steel, The values are

Cp = 40-80
x = 0.86

y = 0.74

z = 1.00

q = 0.86

1. Cutting Force for milling across mounting holes:

$$F_{c1} = C_p \times d_1^x \times S_1^y \times Z \times B \times D^q$$

$$F_{c1} = 60 \times (2.5)^{0.86} \times (0.15)^{0.74} \times 1 \times (5)^{0.86} \times (80)^{0.86}$$

$$F_{c1} = 5603.5 \text{ kg}$$

$$F_{c1} = 5603.5 \times 9.81 \text{ N}$$

$$F_{c1} = 54970.25 \text{ N}$$

$$F_{c1} = 54.97 \text{ KN}$$

2. Cutting Force for milling across cross hole side:

$$F_{c2} = C_p \times d_2^x \times S_2^y \times Z \times B \times D^q$$

$$F_{c2} = 60 \times (1)^{0.86} \times (0.25)^{0.74} \times 1 \times (5)^{0.86} \times (80)^{0.86}$$

$$F_{c2} = 3718.76 \text{ kg}$$

$$F_{c2} = 3718.76 \times 9.81 \text{ N}$$

$$F_{c2} = 36481.06 \text{ N}$$

$$F_{c2} = 36.481 \text{ KN}$$

As Fc1 > Fc2, We have designed fixture considering force Fc1.

Checking for safety of designed vertical plate and base plate:

Length of vertical plate and base plate, L = 200mm

Thickness of vertical plate and base plate, t = 40mm

Yield Strength of plate material, Syt = 200N/mm2

Factor of Safety, Nf = 3

Allowable shear stress:

$$\tau_{all} = \frac{0.5 S_{yt}}{N_f}$$

$$\tau_{all} = \frac{100}{3}$$

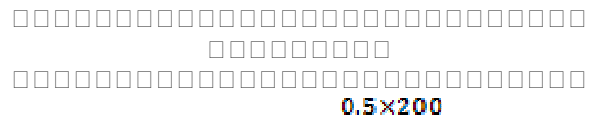

$$\tau_{all} = 33.33 \text{ N/mm}^2$$



33.33N/mm2

Shear Stress on vertical plate:

$$\tau = \frac{F_{c1}}{A}$$

$$\tau = \frac{54970.25}{8000}$$

Where,

A = cross sectional area of plate, mm2

$$= L \times t$$

$$= 200 \times 40$$

$$= 8000 \text{ mm}^2$$

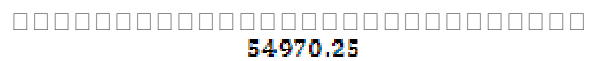

$$\tau = \frac{54970.25}{8000}$$

$$\tau = 6.87 \text{ N/mm}^2$$

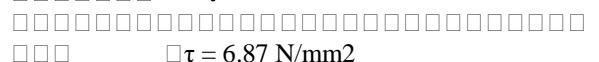

As $\tau < \tau_{all}$, vertical plate is safe against shear failure.

3. MANUFACTURING

A] Part List

Table No:1.1 Part List

SR. NO.	PART NAME	MATERIAL	QUANTITY
01	Base plate	M.S.	1
02	Vertical plate	M.S.	1
03	Pins	20MnCr5	4
04	Locator	20MnCr5	1
05	Swing bolt	En8	2
06	Mandrel	20MnCr5	1
07	Slotted nut	En8	2
08	Support plate	M.S.	2
09	Hinge pin	SAE8620	2
10	Bolt	Standard	3
11	Grub Screw	Standard	2

B] Selection of Materials:

1.0 Mild Steel:-Mild steel is considered the most common type of steel. The cost is relatively small so it is used when large amounts of are needed. M.S is also referred to as low carbon steel. One property of mild steel is that it is malleable as it can be hammered and pressed into any shape. Thus we have used mild steel for base plate, vertical plate and support plate.

2. 0 MnCr5:-20MnCr5 is alloyed case hardening steel for parts with a required core tensile strength of 1000-1300 N/mm² and good wearing resistance as boxes, piston, bolts and spindles. We have used this material for pins locator and mandrel.

3.0 En8:-En8 is an unalloyed medium carbon steel. It is a medium strength steel, good tensile strength. It is suitable for shafts, stressed pins, studs, keys etc. En8 is available as normalized or rolled. The material for swing bolt and slotted nut is En8.

4.0 SAE8620:SAE8620 is a low case hardening steel. It is characterized by good core strength and toughness when carburized, hardened and tempered. It is commercially available in black and bright rounds. It is used extensively by all industry sectors for light medium stressed components. This material is single quenched and tempered, carburized at 9250 C for 8 hr

pot cooled, reheated to 8450 C quenched in agitated oil, 230 0 C tempered, 1.9 mm case depth hardened.

Hinge pins in the fixture are made up of SAE8620.

C] PROCESS SHEETS AND PART DRAWING

PROCESS SHEET – 1

COMPONENT NAME: - Base plate

RAW MATERIAL: - M.S.

RAW MATERIAL SIZE: - 40mm X 205mm X 205mm

QUANTITY: - 1.

Table No. 1.2 Process sheet of Base plate

OPERATION	MACHINE	TOOL USED	TIME
Grinding (Top and Bottom surface grinding)	Grinding machine	Ø180 (46 X 54 grade)	1 Hrs 15 mins
Milling(4 sides) Right angle milling	Milling machine	Face milling cutter ISO30 Ø80 Carbide insert	45 mins
Drilling and Tapping (3 counter bore)	Drilling machine	HSS Drill Ø 12 And Ø 19 mm Tap M12.5	25 mins
		Total Time	2 Hrs 25 mins

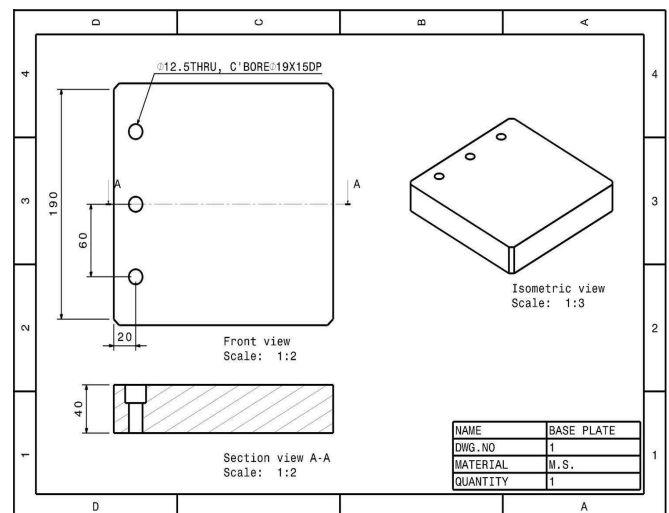

PROCESS SHEET – 2

COMPONENT NAME: - Vertical plate

RAW MATERIAL: - M.S.

RAW MATERIAL SIZE: - 40mm X 185mm X 205mm

QUANTITY: - 1.

Table No. 1.3 Process sheet of Vertical plate

OPERATION	MACHINE	TOOL USED	TIME
Grinding (Top and Bottom surface grinding)	Grinding machine	Ø180 (46 X 54 grade)	1 Hrs 15 mins
Right angle milling (4 sides)	Milling machine	Face milling cutter ISO30 Ø80 Carbide insert	45 mins
Boring (1 hole)	Milling machine	Ø40H7, Eccentric chuck with boring bar and HSS tool (10 X 10)	30 mins
Drilling (4 counter bore)	DRO milling	HSS Drill Ø10 and Ø14 mm	80 mins
Drilling and Tapping (3holes)	DRO milling	HSS Drill Ø11.8 mm Reamer 12mm	20 mins
Slot milling (2 slots)	Milling machine	End mill cutter Ø20	1 Hrs
Drilling(2holes)	DRO milling	HSS tool Ø12mm	15 mins
Drilling and Tapping (2holes)	DRO milling	HSS Drill Ø5mm Tap M6	15 mins
		Total Time	4 Hrs 40 mins

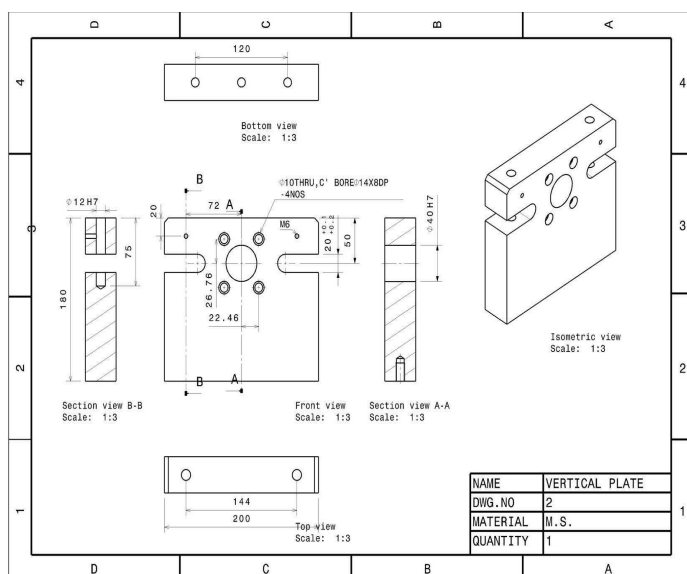

4. ASSEMBLY

A] ASSEMBLY DETAILS:

Refer the assembly sheet:

- Take the Base Plate (1) and keep it over the surface of table
- Mount the Vertical plate (2) over the base plate (1) with the help of standard bolts.
- Now place the Locator (4) over the Vertical Plate (2), fix it properly with the help of pins (3).
- Fix the Swing Bolts (5) in the slots of Vertical Plate (2) with the help of Hinge Pins (9).
- Insert the Grub Screws (11) in the Vertical Plate (2) up to Hinge Pin surface (9)
- Place the Flange Yoke to the Locator (4) and fix it with the help of pins (3).
- Insert the Mandrel (6) through the cross holes of the Flange Yoke
- Screw the Slotted Nut (7) to the Swing Bolt up to the Mandrel Surface (6).
- Weld the Support Plates (8) to the Base Plate (1) and Vertical Plate (2).

B] ASSEMBLY DRAWING

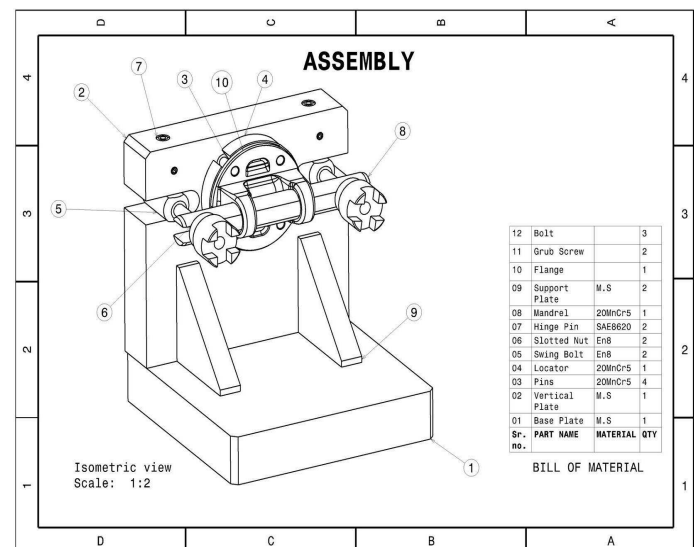

5. CONCLUSION

Hence, with the complete and satisfactory work on “Design and Manufacturing of Flange yoke Fixture” and also after performing result analysis on it, we conclude the following:-

1. With the newly designed fixture vibrations are reduced to a large extent.
2. Using insert milling cutter, tool breakage is eliminated which has been used in place of spot facing cutter.

3.As the problem of tool breakage is reduced machining cost has reduced.

4.Also the cycle time required for machining of component per shift is reduced considerably

References

[1] "Design of Machines Element", R.B.Patil; Tech-max Publications.

[2] "PSG Design data Book"; PSG College of Engineering, Coimbatore, Revised Edition 1997, Pg. No. 1.10, 1.40, 5.42, 5.60, 8.3, 12.26.

[3] "Machine Design", V. B. Bhandari, Third Edition 2008.

[4] "Jigs and Fixtures", D. Hoffman, Thomson Demler Learning Publication, Fifth Edition.

[5] "Design of Machine Tools", S.K. Basu, D.K. Pal, Fifth Edition.